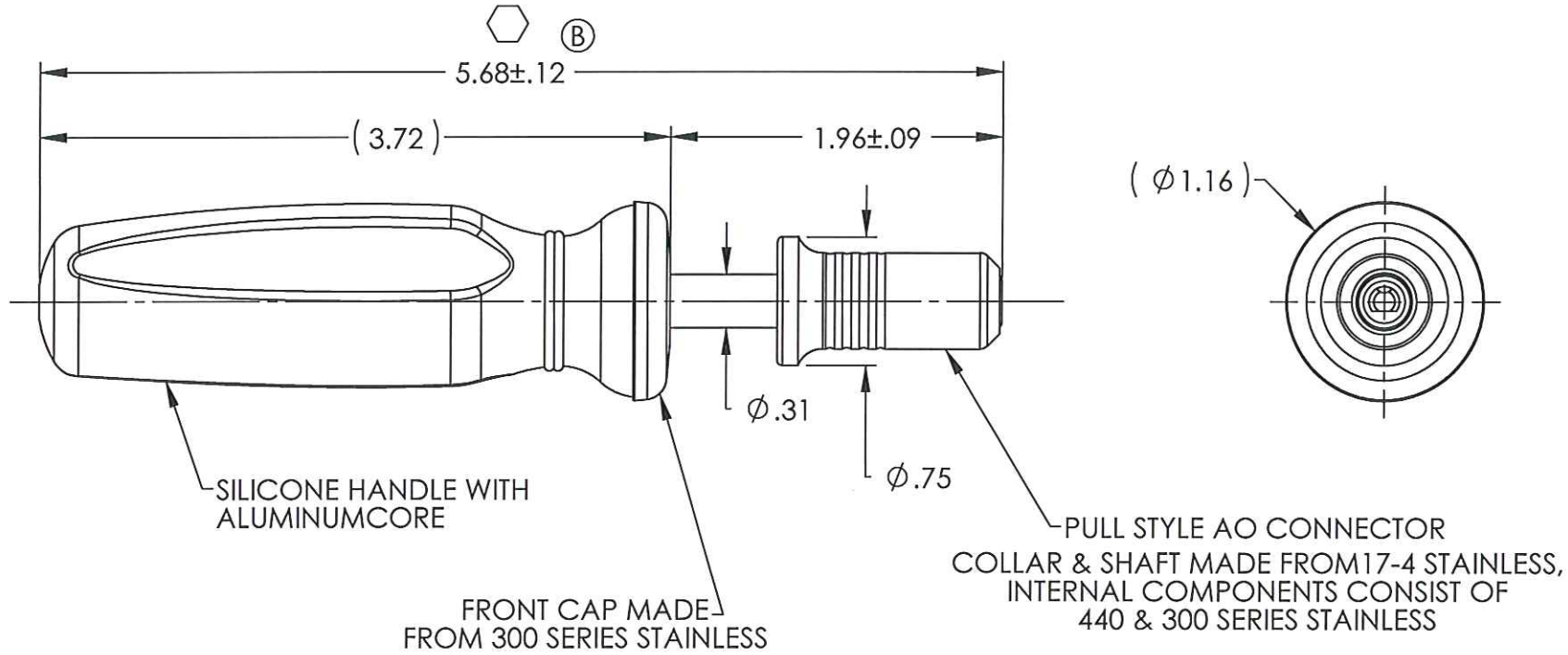

ILLUSTRATION DRAWING REFERENCE ONLY

| REVISIONS | | | |
|-----------|----------------------------------|---------|----------|
| REV. | DESCRIPTION | DATE | APPROVED |
| A | INTERNAL CHANGE | 5/16/05 | SSL |
| B | 5.68±.12 WAS 5.68±.18; ECN 11062 | 2/23/11 | LES |



CUSTOMER APPROVAL

APPROVED BY: _____

DATE: _____

THE INFORMATION CONTAINED IN THIS DRAWING IS THE SOLE PROPERTY OF GAUTHIER BIOMEDICAL, INC., ANY REPRODUCTION IN PART OR WHOLE WITHOUT THE WRITTEN PERMISSION OF GAUTHIER BIOMEDICAL, INC. IS PROHIBITED.

INSPECTION SYMBOLS



UNLESS OTHERWISE SPECIFIED
DIMENSIONS ARE IN INCHES
TOLERANCES ARE:
FRACTIONS DECIMALS ANGLES
±1/32 .XX ±.020 ±1°
.XXX ±.010
.XXX ±.005
.XXXX ±.0005

MATERIAL SEE DETAILS
HEAT TREAT
FINISH
PASSIVATE
ANODIZE

GAUTHIER 
BIOMEDICAL

GAUTHIER BIOMEDICAL, INC.
1235 NORTH DAKOTA DRIVE, SUITE G
GRAFTON, WI 53024
(262) 546-0010 ph. (262) 546-0011 fax
E-mail: engineering@gauthierbiomedical.com

| APPROVALS | DATE |
|-----------------------------|----------|
| DRAWN TJM | 11/11/04 |
| CHECKED <i>[Signature]</i> | 3/03/11 |
| APPROVED <i>[Signature]</i> | 3/03/11 |
| DO NOT SCALE DRAWING | |

| DESCRIPTION |
|--|
| MINI 3-SIDED FIXED HANDLE W\SMALL A-O ADAPTOR |
| SIZE A PART NUMBER G131150 (cc) REV. B |

SCALE 2:1 CAD FILE: G131150 (cc) SHEET 1 OF 1